

Improve productivity and performance while delivering safe-to-ship loads at a lower cost.

Produce **great loads** with more uptime in real world environments

- Power Roller Stretch Plus
- Pallet Grip®
- Option: **LINC®** - an IoT solution

Safety is never an option

- Full fencing comes standard
- PLd electrical & PLC pneumatics as standard
- Designed to keep operators out of harms way

Committed to ensuring machines stay running

- 3-year warranty - no exclusions, unlimited cycles, no exceptions.
- Regionally-based, 24/7 global technical and customer support
- Most parts ship same day

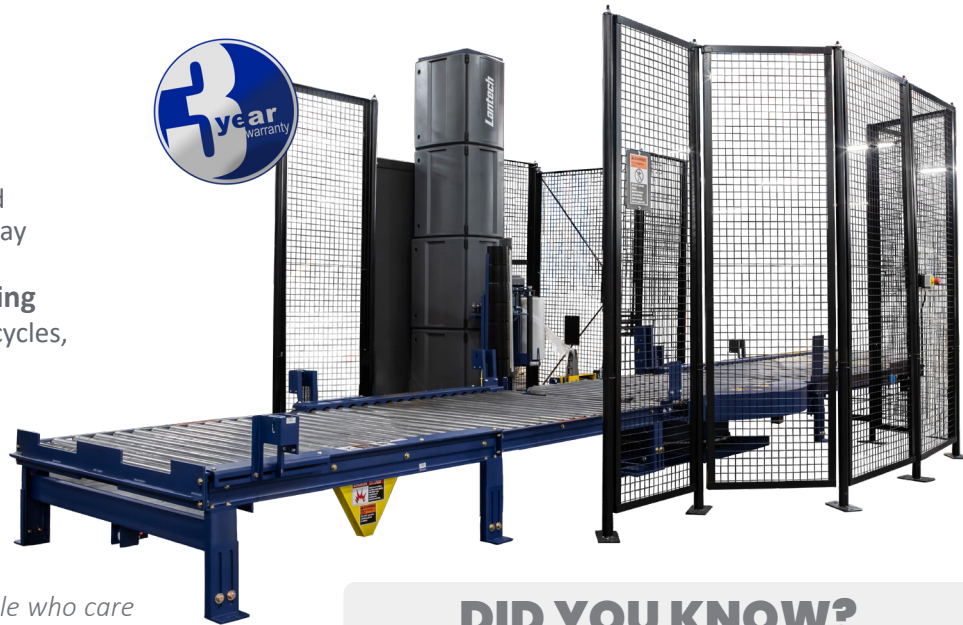

"When you buy Lantech, you will always have people who care and who know more about wrapping pallets than anyone else in the world, ready to support you."

-Jim Lancaster, CEO Lantech

DID YOU KNOW?

The Damage Prevention & Freight Claim Committee of the Association of American Railroads recognizes Pallet Grip® as an approved securement solution due to its proven ability to prevent product damage in transit.

Click or Scan to Read More From Jim



Power Roller Stretch Plus



Responds faster and more accurately

- Better corner compensation
- Minimizes corner/product crushing
- 225% pre-stretch standard

NEW



Pallet Grip®



Lock your load to the pallet

- Stops loads from sliding off pallets during transit
- Reduces returned goods and transit damage
- Lowers costs and carbon footprint

NEW



Year Warranty



Best in Class

- No exclusions
- Unlimited Cycles
- No exceptions
- [Click Here](#) to learn more about our Lantech Built Tough Warranty



An IoT Solution

- Remote monitoring system
- Actionable analytics
- Live notifications anytime, anywhere
- [Click here](#) to learn more

NEW
OPTION

Standard Specifications - options available	
SPEC ITEM	GLOBAL SPECS
PERFORMANCE	
Production Speed	1-45 LPH Standard
Maximum Load Size	1371 mm L x 1219 mm W x 2337 mm H 54" L x 48" W x 92" H
Minimum Load Size	914 mm L x 914 mm W x 610 mm H 36" L x 36" W x 24" H
Maximum Load Weight	4000 lbs
LOAD HANDLING AND FILM DELIVERY SYSTEM	
Rotation Speed	1-15 RPM
Pre-stretch	225%
Film Capacity	508 mm Web with 254 mm Diameter 20" Web with 10" Diameter
Film Cut and Clamp	Jaw Clamp with Hot Wire
Film Delivery System	Power Roller Stretch Plus
Pallet Grip®	Standard
ELECTRICAL	
Power	460VAC/3/60Hz
Control	PLC with Ethernet Communications
Motor Control	AC Motors Safe-Torque Off (STO)
HMI	AB PanelView 800
PLC	AB Micro 800 Series
Wiring	Some pre-wired quick connect cables for easy assembly
PNEUMATIC	
Pneumatic Data	3-5 cfm @ 80 PSI
SAFETY	
Fencing	In accordance with BS EN ISO 13857 Standard
Performance Level	In accordance with ISO 13849-1 Standard
SERVICE SUPPORT	
Warranty	3 Year Unlimited Cycle Coverage
24/7 Technical Support	1 (800) 866-0322

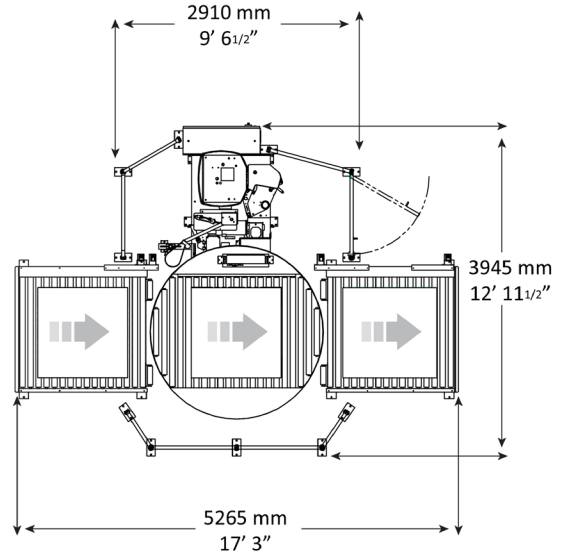

Shown with optional infeed and exit conveyors

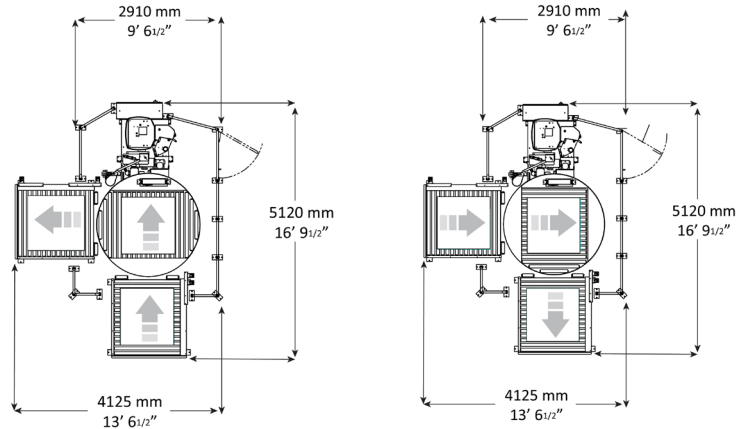

Multiple non-standard configurations possible to meet your space requirements

Click or Scan to Learn More



QA Product Video



Pallet Grip Video



Lantech.com