

LA-Parcel

Lid Applicator

- Small footprint, compact machine
- Ergonomic blank magazine
- Fully enclosed design
- Speed 1000 trays per hour
- Simple, accurate adjustments
- Change lid sizes in 7 steps



Industries and Applications

- **E-Commerce**
 - Jewelry, Chocolate, Books, Electronics, Cosmetics, Cooking, Wellness and More
- **Fulfillment**
 - Piece by piece
- **Letterbox delivery**
 - No recipient required
- **Less expensive to ship**
 - Maximize packages in trucks
 - Stackable and stable

Sustainability

- **Reduce package waste**
 - Eliminate excess materials
- **Reduce product damage**
 - Crushing effect prevents breakage
 - No air packed in tray
 - No filling materials required
- **Reduce returned goods**
- **Reduce rework & materials**
- **Reduce landfill impact**
- **Reduce carbon footprint**

LA-Parcel

How Lantech Lid Applicators make Square Lids

As with the tray erector, the lid applicator blank is under full control from the moment it enters the magazine until it exits the lid applicator as a correctly finished lidded case/ tray. The lid is removed from the magazine and tilted so that it is horizontal. The pick and place (X-Z movement) with the forming head attached, picks up the lid and moves it along a defined path to the finished case/ tray. The lid is positioned over the case/tray, the 4 side flaps are folded 90° and placed on the case/tray. During this transfer, glue is applied to 4 sides of the lid to close. Finally the formed package exits the machine.

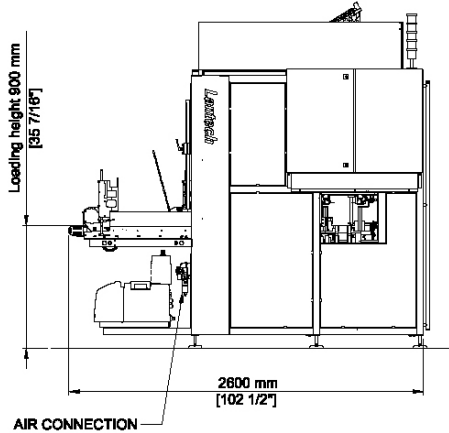
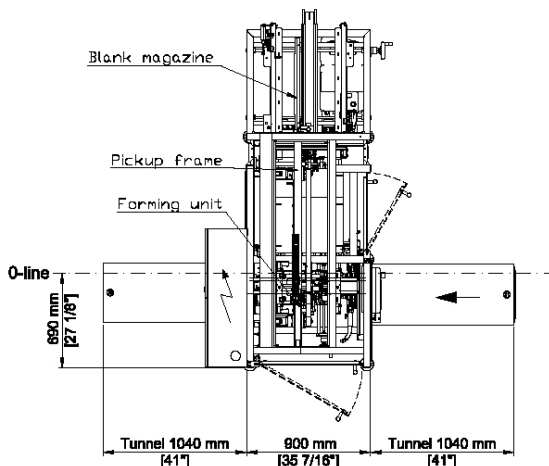

LA-Parcel

Standard Specifications - options available

SPEC ITEM	GLOBAL SPECS
Speed	1000 Lids per hour Options and application can change the speed
Minimum Incoming Tray Size Outer Dimensions	165 mm A x 115 mm B x 20 mm C
Maximum Incoming Tray Size Outer Dimensions	400 mm A x 300 mm B x 200 mm C
Maximum Weight Incoming Tray	3 kg
Lid Size Minimum Outside Dimensions	165 mm A x 115 mm B x 20mm C
Lid Size Maximum Outside Dimensions	400 mm A x 300 mm B x 40 mm C
Minimum Lid Blank	210 mm L x 160 mm W
Maximum Lid Blank	480 mm L x 400 mm W
Lid Type	FEFCO 0458
Flute Type	E, C, B
Wall Type	Single
Throughput Height	900 mm - Standard equipment for one tray height
Random Tray Heights	Optional actuator for multiple tray heights
Standard Sealing Device	Hotmelt Robatech
Dimensions - Machine	2600 mm L x 2980 mm W x 2540 mm H
Electrical Service	3L-PE-400V-50Hz Neutral
Pneumatics	6 Bar (80 PSI)
Blank Magazine Capacity	500 Blanks

Click or Scan to Learn More



LA Parcel Video



TE Parcel Leaflet



Lantech.com

Lantech North America · 11000 Bluegrass Parkway · Louisville, KY 40299 · USA · +502 815 9109
 Lantech Europe · Sluisweg 20 · 6581 KA Malden · The Netherlands · +31 (0) 485 751 760
 Lantech Asia Pacific · 86 Wedgewood Road · Hallam, VIC 3803 · Australia · +61 3 9796 5275
 Lantech China · Suit 13E2 Shanghai Industrial Investment Building · 18 Caoxi Bei Road · Shanghai 200030 · +86 21 6427 1962